

Building Restoration

Complete Concrete Repair and
Protection Systems From Sika



TABLE OF CONTENTS

CONCRETE PROPERTIES	
Materials, Function and Limitations.....	1
SUCCESSFUL CONCRETE REPAIR	
Based on Identifying the Root Cause.....	2
MAJOR CAUSES OF CORROSION	
Carbonation and Chlorides.....	4
REPAIR AND PROTECTION REQUIREMENTS	
Visible and Latent Damages.....	5
REQUIREMENTS BEFORE REPAIR	
Survey and Diagnosis.....	6
REQUIREMENTS BEFORE REPAIR	
Bid Preparation and Contractor Selection.....	7
REQUIREMENTS DURING REPAIR	
Diagnosis, Workmanship, and Project Management.....	8
REQUIREMENTS FOR A LASTING REPAIR	
Durability and Protection.....	9
SIKA SYSTEM APPLICATION	
Product Installation Guide.....	10
CONCRETE REPAIR AND PROTECTION	
Flow Chart of the Process.....	12
COMPLETING THE PACKAGE	
Additional Compatible Sika Systems.....	13



Concrete Repair and Protection Project in Progress

CONCRETE PROPERTIES

Materials, Function, and Limitations

Concrete Properties

Concrete's properties are determined by the selection and proportions of the main constituents. These are cement, aggregates, water, and increasingly, admixtures. The water/cement ratio, compaction and curing are particularly important. On site, however, concrete is used in situations which are far from the ideal environment. Here its performance is influenced not just by the material selection, but by a number of other factors. These include design, workmanship and exposure.

- ▲ When designing the structure, it is important to consider the dimensions of the concrete, the reinforcement positioning, concrete density and protection, the intended procedures for maintenance, and the intended life expectancy.
- ▲ Good workmanship involves paying sufficient attention to formwork detailing, the degree of vibration and compaction of the concrete, finishing techniques, compliance with the correct construction standards, and curing.
- ▲ Concrete structures may be subject to various types and levels of exposure. These may include: immersion, the action of de-icing salts, the marine environment, other chemical contact, impact, abrasion, and extremes of temperature, with frequent freeze/thaw cycling.

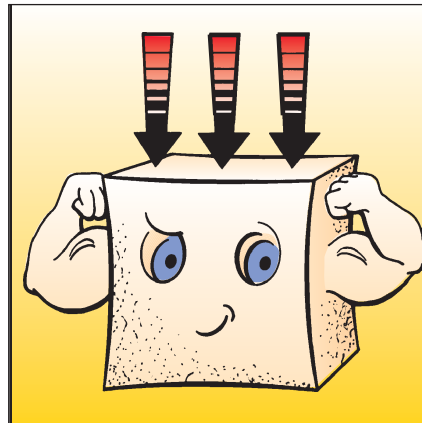

Concrete is Good in Compression

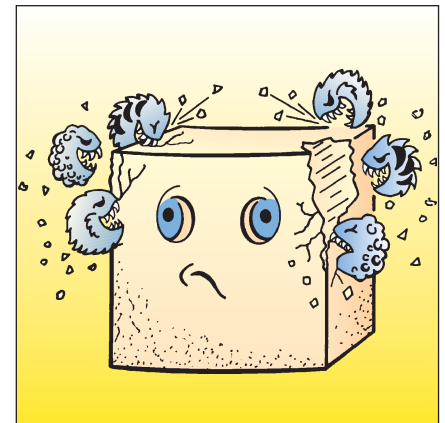

Concrete is Always Under Attack

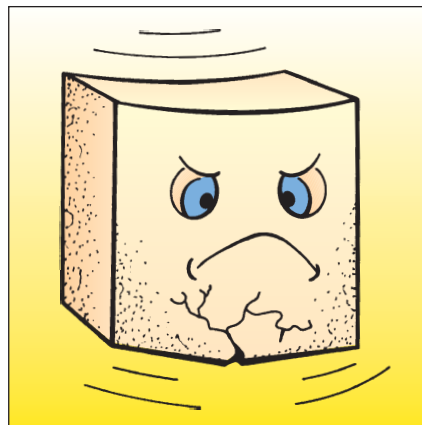

Concrete is Poor in Tension

Concrete is strong in compression, but comparatively weak in tension. The inclusion of steel reinforcement improves the tensile strength of the element and, consequently, its resistance to stress.

Unfortunately, in the presence of water and oxygen, steel corrodes. Therefore, in almost all likely exposure conditions for reinforced concrete, corrosion of the steel is a potential hazard.

Fortunately, the inherent alkalinity of concrete has a passivating action on steel surfaces. This means that when steel reinforcement is provided with concrete cover of adequate quality and thickness, corrosion is prevented. This allows reinforced concrete to perform its load carrying function in construction.

SUCCESSFUL CONCRETE REPAIR

Based on Identifying the Root Cause

START

Typical Concrete Problems



Rust Staining



Cracking



Spalling

ROOT
CAUSE?

Steel Reinforcement Corrosion

Corrosion of Steel in Concrete

Concrete is a highly alkaline material when first produced, (pH range 12.7–13.2), and embedded steel is well protected by the passive oxide layer formed by the initial high alkalinity at the surface of the steel.

While this alkaline protection is usually effective for a long period of time, it is dependent on the absence of surface defects, permeability and the depth of concrete cover over the steel reinforcement. As an electrochemical process, corrosion of steel in concrete requires an electrolyte.

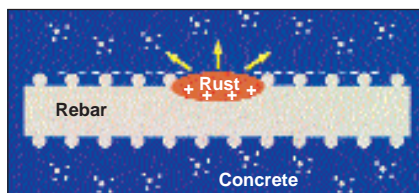

Concrete is full of small pores which contain moisture and is an effective electrolyte. A small electrical current flows between anode and cathode with corrosion activity taking place at the anode.

The corrosion products of steel are known as "RUST" (chemically, iron oxides and hydroxides), which have a much greater volume than the steel

(up to 8-12 times the volume). This increase in volume is progressive, gradually exerting greater and greater expansive forces within the concrete. The ultimate result is stress relief through cracking, first visible as rust staining, followed by larger cracks, and then spalling over the corroded reinforcement.

Both the relative humidity and the temperature have a significant bearing on the speed of corrosion in concrete. The corrosion rate increases with temperature rise and reduces with a drop in relative humidity.

SUCCESSFUL CONCRETE REPAIR

Based on Identifying the Root Cause

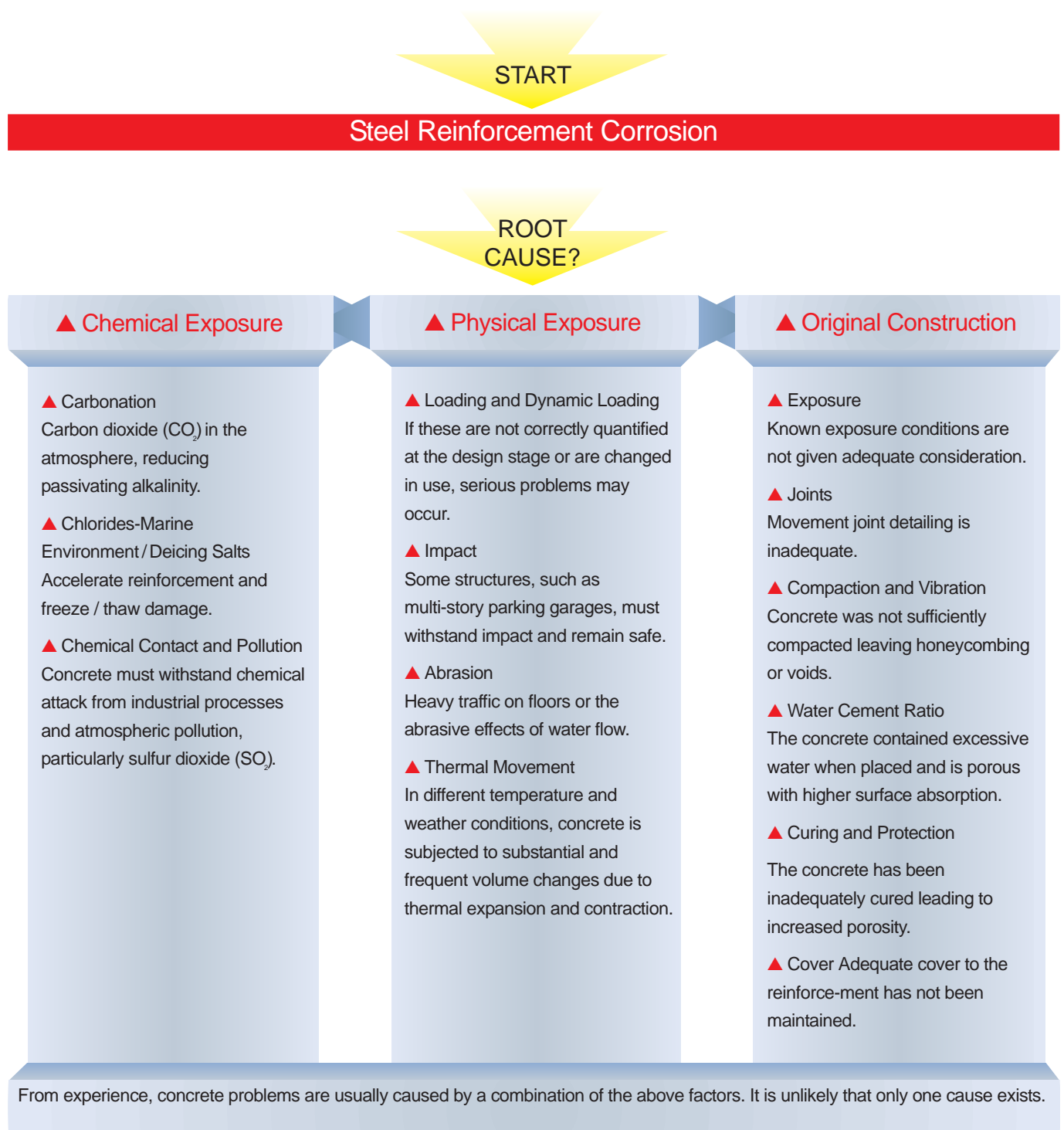

MAJOR CAUSES OF CORROSION

Carbonation and Chlorides

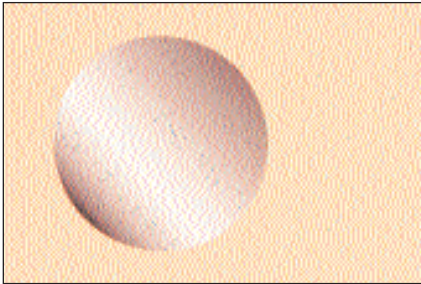

Good Quality Concrete (pH = 12.7-13.2)
Steel is Passivated

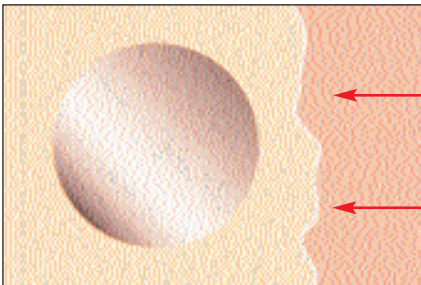

Carbon Dioxide Enters, pH Begins to Drop.
Steel is Not Yet Affected



pH at Steel Drops Below 9.5,
Corrosion Begins



Volume Expansion of Rust Causes
Cracking and Spalling

Carbonation of Concrete

The most common cause of loss of passivating alkalinity is carbonation—a process whereby atmospheric carbon dioxide reacts with the soluble alkaline calcium hydroxide and other cement hydrates in the concrete. These are then converted into insoluble calcium carbonate. This process is completely natural. However, the alkalinity of the cement matrix is reduced and its passivating ability is lost progressively from the surface inward. The speed of penetration depends largely upon the permeability of the concrete and its moisture content or humidity.

For carbonation to take place, moisture must be present. The carbonation reaction proceeds most rapidly when the relative humidity is between 50 percent and 75 percent. At lower humidities, there is insufficient water in the pores of the concrete for significant quantities of calcium hydroxide to dissolve. Above 75 percent humidity the situation is reversed and the pores become progressively blocked with water, allowing the calcium hydroxide to freely dissolve but largely preventing the ingress of carbon dioxide.

It is important to remember that cracks, bugholes, honeycombing, day-joints, etc., are all critical areas which may permit the ingress of corrosion promoting substances and effectively reduce the actual thickness of the concrete cover.

Once the concrete in contact with reinforced steel has carbonated, the reinforcing steel is no longer protected. In the presence of moisture and oxygen, corrosion damage is inevitable.

Chlorides in Concrete

The potential for reinforcement corrosion is greatly enhanced if chlorides are present in the concrete.

Chlorides can enter the concrete through direct or indirect exposure of the structure to deicing salt, exposure in a marine location, use of contaminated original materials, or perhaps leakage from a swimming pool. The concentration of chlorides required to promote corrosion of embedded reinforcement is affected by the pH of the concrete. The pH of fresh concrete (12.7–13.2) a threshold level of about 7,550–8,000 ppm is required to start corrosion on embedded reinforcement but if the pH is lowered to 10.5–11.5 (still sufficient to turn phenolphthalein solution purple) the chloride threshold is significantly lower, at below 100 ppm.

In addition to their electrochemical influence on the initiation and rate of corrosion, chlorides also can cause physical damage to the concrete surface. This is due in effect to ‘thermal shock’ resulting from accelerated freeze/thaw cycles. Progressive surface spalling can occur, reducing or eliminating cover to steel reinforcement.

REPAIR AND PROTECTION REQUIREMENTS

Visible and Latent Damages

Prevention of Latent or Future Damage

▲ It is absolutely essential that the root causes of damage are identified

Most defects will initially become evident at locations where there is low cover and/or poor quality concrete. The *reasons for damage*, however, usually require greater investigation. It is important to carry out technically correct repairs, *not just to treat the symptoms*, but also to treat the latent damage to *prevent* continued deterioration.



Successful Repair Requirements

▲ To ensure long-term protection, the remedial treatment must satisfy the following basic criteria:

- ▲ Any corroding reinforcement should be cleaned and then protected, preferably in an impervious alkaline environment.
- ▲ A strong bond should be created between the repair materials and the original concrete.
- ▲ Where necessary, repair materials should have a similar thermal expansion coefficient to the original concrete.
- ▲ Water vapor diffusion resistance should be similar to that of the original concrete.
- ▲ The system should offer active corrosion inhibition.
- ▲ The treatment should offer a high resistance to future carbon dioxide and chloride ion ingress.
- ▲ Materials should be physically compatible with any structural requirements. Particularly important is that they do not have excessively high compressive strength or higher modulus (and therefore increased rigidity) making them prone to failure. The ideal materials will have similar compressive strengths with lower modulus of elasticity to give minimum stress to the parent concrete.
- ▲ All materials should be supplied by a manufacturer with a **proven quality management system such as ISO 9000**.

▲ Depending on the nature of the structure, its function and exposure, the following points may also be of importance:

- ▲ The structure should be aesthetically pleasing.
- ▲ Profiles and uniformity of concrete elements should be restored.
- ▲ Improvement of the environment by the strategic use of color can be considered.

Contractor Evaluation and Selection

In addition to the materials selection and assessment, a thorough evaluation of prospective contractors must be undertaken. This should include checking references of similar works and assessment of technical competence, management structure, any other relevant experience, and of course, financial standing and ability to fund the project throughout its duration.

REQUIREMENTS BEFORE REPAIR

Survey and Diagnosis



Hammer Testing for Soundness



Covermeter Survey to Determine Depth of Steel Reinforcement



Carbonation Depth Testing with Phenolphthalein

Preliminary Survey and Diagnosis

This initial survey and diagnosis provides the information which will form the basis of the repair activity. It is, therefore, absolutely essential that these operations be carried out by suitably qualified and experienced personnel.

Independent professional organizations exist to carry out this work. Wherever possible, the use of an independent testing company is recommended to confirm the reasons for damage. It is important to do this even when the initial survey to determine the extent of damage can only be undertaken in conjunction with the selected specialist repair contractor.

The first step is always to conduct a visual examination of the damaged structure, noting all symptoms and recording with photographs. This should then be combined with testing, using principally non-destructive techniques onto *cleaned concrete* in order to determine the following:

- ▲ Strength of concrete (rebound/schmidt hammer).
- ▲ Depth of concrete cover and reinforcement location (covermeter).
- ▲ Depth of carbonation zone (chemical indicator test, such as phenolphthalein).
- ▲ Chloride content (by weight of cement).
- ▲ Concrete permeability (initial surface absorption test).

A number of other test procedures, e.g., petrographic examination, electropotential mapping, etc., may also be useful in compiling a complete picture of the structure, the damage and the causes.

It is important that the structure is assessed as a whole; of particular importance are the soundness of existing waterproofing systems, evidence of structural movement and structural integrity.

These will determine the order in which the works should be programmed and if additional or separate works are a prerequisite. This would include the rewaterproofing of balconies, decks or roofs prior to start.

The results of all these tests require skilled and accurate interpretation- so that any unusual aspects of the concrete, the rest of the structure and the environment do not go unnoticed. Consequently, this diagnosis should be made only by personnel with suitable experience in concrete and its deterioration. In all cases it is recommended that this be undertaken under the supervision of an experienced and independent structural engineer.

The Sika computerized CRS service is available to help with the next stage of preparing the specification and bid documents.

REQUIREMENTS BEFORE REPAIR

Bid Preparation and Contractor Selection

Specification and Bills of Quantities

Repair is not a standard process. Each individual contract must take into account special factors, such as access, protection and coordination with other trades, and measurement needs to accommodate possible variations from initial quantity items. No matter how much survey work is undertaken at the start, it is unlikely that the depth and area of each repair will be known beforehand.

Standardization of this approach will obviously aid the engineer's initial cost assessment and the contractor's estimating and billing function to the benefit of the client. It will also assist documentation, assignment of valuation for work in progress, and final measurement.

The specification should cover: progressive investigation and testing, surface cleaning, preparatory work and the precise nature and sequence of the repair and protection operations. It should clearly describe the materials and relate to standards, including details of their application and performance characteristics, weather precautions and works protection, material thicknesses, consumptions and curing procedures.

As the quantities for repair works can only be assessed approximately in advance, accurate Bills of Quantities are difficult to compile, and it is fair and sensible to allow for re-measurement of the actual repairs carried out.

The repairs should therefore be defined with regard to the materials and application methods to be used, the areas to be treated and the Method of Measurement.

With the standard System of Measurement and the Bills of Quantities developed by Sika Corporation, it is possible to produce accurate costs for all but the precise number and volume of repairs to be made. Thus, special attention should be given to this area in the survey works and allowances made in budgets for likely increases in both the number and size of repairs, i.e., to include those identified as areas of latent damage through the initial and the ongoing testing work.

The majority of the costs can be billed accurately. For instance, cleaning, access, protection of works, surface leveling, protective impregnation and coating applications, these all relate closely to the specific surface area of the structure which is easily measured in advance and on completion. This outline Specification and Bills of Quantities developed by Sika Corporation provides valuable assistance. It enables standardized comparison and evaluation of bids, with minimal additional change orders.

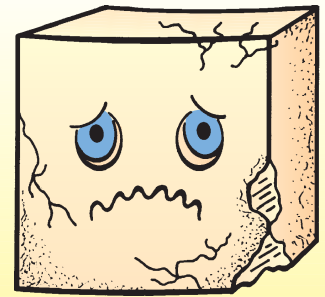

“The bitterness of poor quality remains long after the sweetness of low price is forgotten”

REQUIREMENTS DURING REPAIR

Diagnosis, Workmanship, and Project Management



Repair Project in Initial Surface Cleaning Phase



High Pressure Water Cleaning Before Marking out for Repairs

Progressive Diagnosis

Successful concrete repair works require that all areas of damage and latent damage are treated effectively.

On-site tests must always be carried out by experienced operatives.

Accurate results will only be obtained if the tests are carried out on the concrete surfaces after they have been cleaned. The cleaning operation itself will often bring to light additional 'visible defects' and provide a true surface for assessment—particularly covermeter readings and crack location.

Workmanship

As many buildings under repair are occupied, the contractor must strive to maintain a good relationship with the owner or tenants. Where owner residents' associations exist, we strongly recommend that they are involved at the earliest possible stage. Potential problem areas of noise, dust and color selection cause minimum contract disruption when dialogue is started early and maintained.

Project Management

All parties involved have professional and contractual obligations. However all parties must be vigilant in quality management of the works. This should include:

- ▲ The Engineer
- ▲ The General Contractor (if applicable)
- ▲ The Specialist Concrete Repair Contractor
- ▲ The Repair System Manufacturer.

Site quality management ensures consistency of the correct standards in the works actually carried out.

When working on site, there has to be a continuing awareness of the changing state of the building, access, working methods, varying weather conditions and human failings. As progressive testing may reveal the unexpected, there also has to be an ability on the part of all parties to adapt and incorporate additional elements into the contract.

The Engineer provides guidance in all aspects of the contract. For items which are of structural importance, such as the repair of load bearing elements, the engineer must identify locations where the load must be supported before the damaged concrete is broken out.

REQUIREMENTS FOR A LASTING REPAIR

Durability and Protection

Protective Coating System

To be fully effective, a protective coating must be applied to a defect-free and level surface.

Imperfections in the protective film will allow ingress of aggressive gases and liquids making the protective treatment ineffective.

The Repair and Protection System

The objective in using the Sika concrete repair and protection system is to provide the structure with effective, safe and proven repair. This halts the progress of latent damage and ensures lasting protection for areas not specifically repaired.

Inadequate concrete cover is replaced by Sika's efficient system to prevent future reinforcement corrosion. Sika's active corrosion inhibitor protects at both anode and cathode areas.

Sika's protective surface coatings prevent penetration by water, carbon dioxide and other aggressive atmospheric influences. Yet, they function fully in accordance with standard building physics, allowing each way water vapor diffusion and accommodating normal hygrothermal movements. Sikagard Elastocolor also providing dynamic crack bridging protection even at extremes of temperature.

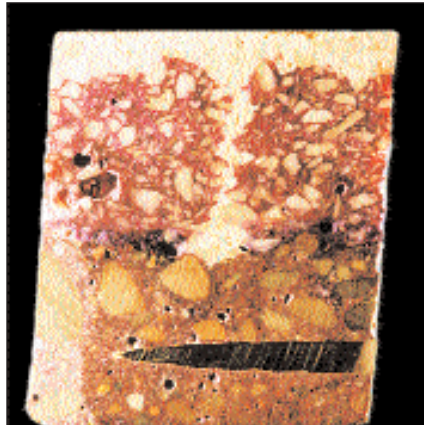

Cross Section of Concrete Showing Increased Depth of Carbonation Through Fine Surface Crack

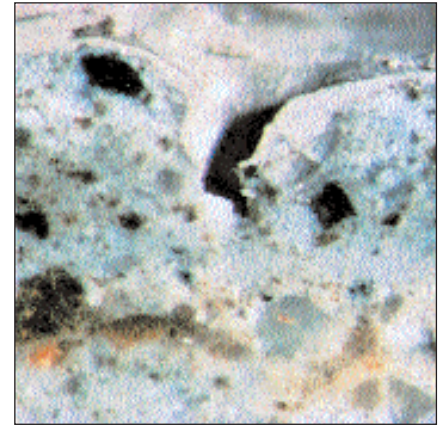

Unfilled Bughole Showing Break in Protective Coating



Successfully Completed Repair and Protection Projects with the Complete Sika System Approach

SIKA SYSTEM APPLICATION

Product Installation Guide

1. Treat Any Exposed Steel

Sika Armatec® 110 EpoCem protects against corrosion and improves the bond of repair mortars.

- ▲ Protects reinforcement in a high alkaline cementitious environment.
- ▲ Can be applied on the damp surface obtained with SSD dampening.
- ▲ Increases barrier to water and chlorides.
- ▲ Fully compatible with load transfer requirements.
- ▲ Ensures homogeneous bond.

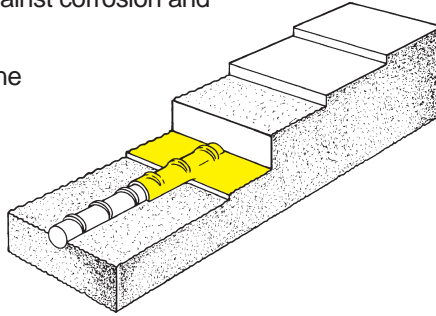

Brush Application of Sika Armatec 110 EpoCem on a Soffit

2. Repair the Spalls

Sika MonoTop® repair mortars are easy-to-use one pack polymer-modified mortars for replacing the concrete in spalled areas.

- ▲ High build for security of application.
- ▲ Easy to use, vertically or overhead.
- ▲ Physical properties closely match parent building concrete.
- ▲ Lower modulus for increased durability in high thermal movement (i.e., on building facade elevations).

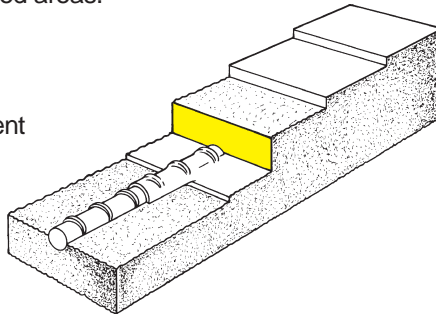

Trowel Application of Sika MonoTop

Sika MonoTop mortars require no special curing procedures and should simply be protected in accordance with standard practice. The best protection is wet burlap and/or plastic sheeting.

NOTE: Curing compounds of any type are not recommended due to their unreliable site performance and their detrimental effect on the bond of subsequent materials.



Spalls filled with Sika MonoTop Ready for Leveling and Protection

3. Protect from Future or Latent Damages

Sika FerroGard® 903 is a corrosion inhibiting impregnation that penetrates and protects not only the repair area, but also the surrounding concrete from future corrosion due to latent damages.

- ▲ Performance not dependent on chloride levels.
- ▲ Active cathodic and anodic passivation.
- ▲ Totally nitrite free (non-toxic).
- ▲ Can penetrate to the reinforcement in one week.

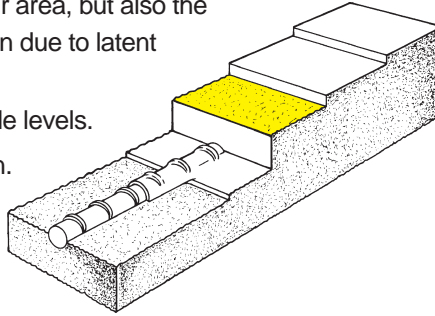

Spray Application of Sika FerroGard 903 on a Parking Deck

4. Level and Waterproof the Surface

Sika Leveling Mortars are protective leveling mortars which restore a level profile to the concrete and effectively waterproof the surface.

- ▲ Fills bugholes and minor surface defects.
- ▲ Provides an ideal substrate for protective coatings.
- ▲ Application method controls consumption to needed volume only.

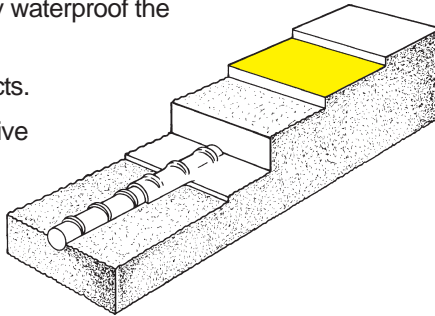

Trowel Application of Sika Leveling Mortar on a Parapet

5. Protect from Carbonation

Sikagard® Elastocolor® is a protective, decorative and dynamically crack-bridging coating which protects the entire structure from the harmful effects of carbonation and water ingress.

- ▲ Bridges dynamic moving cracks up to 12 mils (0.3 mm) at 16 mils (400 microns) dry film thickness.
- ▲ Effectively halts carbonation.
- ▲ Allows each way water vapor diffusion.
- ▲ Prevents water and chloride ingress.
- ▲ Enhances the appearance.
- ▲ Gives excellent design opportunities with durable color.

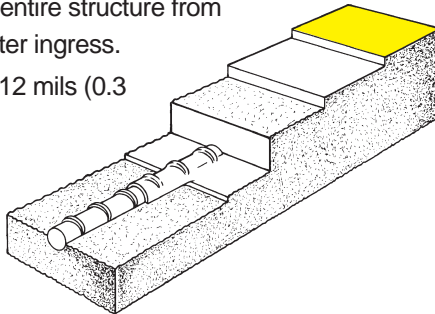

Roller Application of Sikagard Elastocolor

COMPLETING THE PACKAGE

Additional Compatible Sika Systems

Joint Sealing with Sikaflex® High Performance Sealants

Sika's high performance one and two component polyurethane joint sealants are fully compatible with Sika's concrete repair system. Sikaflex 15LM is probably the best joint resealing sealant available because of its high movement capabilities, its non-sag characteristics, and most important, its tolerance of the damp and variable substrate conditions common in restoration works.



Sikaflex 15LM Sausage Ready for Gun Application

Deck Surfacing and Waterproofing with Sikafloor® Traffic Systems (SFTS)

Sikafloor Traffic Systems provide horizontal protection with high performance, crack bridging, wearing surfaces for areas adjacent to the concrete repair works including parking garages, public and private balconies. Indeed, in parking garage and balcony work, resurfacing and waterproofing are often a prerequisite to successful repair and protection.



Trowel Application of Sikafloor Traffic System on a Public Balcony

Crack Injection with Sikadur® Epoxy Systems

Cracks or voids can be successfully sealed to restore structural integrity. Sika provides a full range of products, systems and application advice for all types of resin injection and grouting work.



Sikadur Injection System on a Building Facade

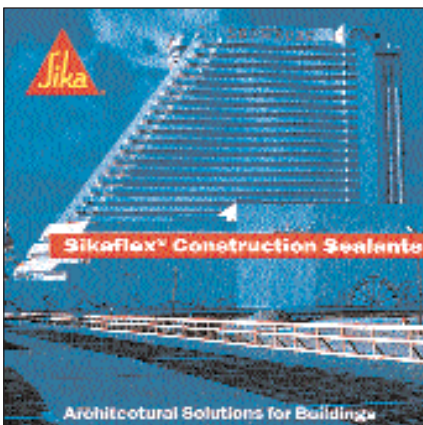

Sikaflex on the Showboat Casino (Cover from the Sikaflex Construction Sealants Brochure)



Sikafloor Traffic System on a Parking Garage



Sikafloor Traffic System on a Private Balcony

COMPLETE CONCRETE REPAIR AND PROTECTION SYSTEMS FROM SIKA

Worldwide References

Sika Corporation is undoubtedly the most qualified partner in building restoration works. Our extensive experience in North America is complemented by our worldwide research and development programs.

Case studies are available for almost all types of building structures, in all types of environmental exposure, at all extremes of temperature, and in all geographic regions. Specific details can be obtained on request.

Sika is also experienced worldwide with Civil Engineering works and details of our products, systems, and services here are also available on request.

Technical and computer-generated specification components are available immediately via fax. Call your local Sika Tech Center at 1-800-933-SIKA

SC-200 Sika® Armatec 110 Bonding Bridge

1. Pre-wet surface to saturated surface dry (SSD).
2. Apply by stiff bristle brush or spray apply with "Goldblatt pattern pistol" or equal equipment.
3. Place repair material while Sika Armatec 110 is still wet or dry up to 24 hours.

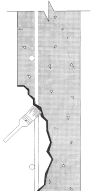

SC-135 Sika MonoTop® 615 Hand-applied (Horizontal, Vertical, and Overhead)

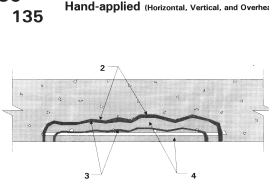

SC-135 Sika MonoTop® 615 Crack Filler (Horizontal, Vertical, and Overhead)

1. Repair area should be no less than 1/8" in depth.
2. Apply scrub coat to prepared substrate.
3. While scrub coat is still wet place Sika MonoTop filling the entire cavity.
4. Strike off and level as required.

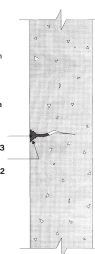

SC-059 Elastocolor® Surface Coating (Textured)

1. Substrate must be dry, clean and sound.
2. Apply ElastoColor by brush, roller or spray over entire area moving in on direction.



1-800-933-SIKA NATIONWIDE
Regional Headquarters and Sales Centers

For the location of your nearest Sika sales office, contact your regional center.



Sika Corporation (USA)
 201 Polito Avenue
 Lyndhurst, NJ 07071
 Phone: 201-933-8800
 Fax: 201-933-6225

Sika Mexicana S.A. de C.V.
 Carretera Libre Celaya Km. 8.5
 Corregidora, Queretaro
 C.P. 76920 A.P. 136
 Phone: 52 42 25 0122
 Fax: 52 42 25 0537

Sika Canada, Inc.
 601 Delmar Avenue
 Pointe Claire,
 Quebec H9R4A9
 Phone: 514-697-2610
 Fax: 514-694-2792

SIKA...A SYMBOL OF STRENGTH SINCE 1910

The information contained in this document(s), including but not limited to any recommendations regarding the use and application of Sika Corporation ("Sika") product(s), is given in good faith based on Sika's current experience and knowledge of its products when properly stored, handled and applied under normal conditions in accordance with Sika's instructions. The information contained in this document(s) is valid only for the applications and uses of Sika product(s) described herein. Any deviation from any of the instructions, uses, applications and recommendations contained in this document(s) regarding the Sika product(s) will void any Sika warranty. The user of the Sika product(s) must test each product for suitability for the intended application and purpose. The user of Sika product(s) must always read and follow the warnings and instructions for each product on the current Technical Data Sheet, product label and Material Safety Data Sheets prior to product use. All sales of Sika product(s) are subject to its current terms and conditions of sale available at www.sikacorp.com or 201-933-8800. Technical Data Sheet(s) and Material Safety Data Sheet(s) are available at www.sikaconstruction.com. Nothing contained in any Sika materials relieves the user of the obligation to read and follow the warnings and instructions for each Sika product as set forth in the current Technical Data Sheet, product label and Material Safety Data Sheet. Sale of Sika product(s) are subject to the following Limited Material Warranty: Sika warrants this product for one year from date of installation to be free from manufacturing defects and to meet the technical properties on the current Technical Data Sheet if used as directed within shelf life. User determines suitability of product for intended use and assumes all risks. Buyer's sole remedy shall be limited to the purchase price or replacement of product exclusive of labor or cost of labor. NO OTHER WARRANTIES EXPRESS OR IMPLIED SHALL APPLY INCLUDING ANY WARRANTY OF MERCHANTABILITY OR FITNESS FOR A PARTICULAR PURPOSE. SIKA SHALL NOT BE LIABLE UNDER ANY LEGAL THEORY FOR SPECIAL OR CONSEQUENTIAL DAMAGES. SIKA SHALL NOT BE RESPONSIBLE FOR THE USE OF THIS PRODUCT IN A MANNER TO INFRINGE ON ANY PATENT OR ANY OTHER INTELLECTUAL PROPERTY RIGHTS HELD BY OTHERS.