

SIKALASTIC®-500 SYSTEMS SILICONE ROOF SYSTEM

BUILDING TRUST



QUICK SPECIFICATION: SYSTEM COVERAGE FOR CONCRETE

DESCRIPTION

The Sikalastic®-500 system for concrete is a high volume solids elastomeric silicone coating system that provides superior weather-proofing and high UV resistance over a variety of roof substrates.

BASIC USES

Sikalastic®-500 is a tough, durable application designed to extend the life of a wide range of roof top environments from premature weathering and moisture intrusion. It is effective as a protective membrane to coat an entire roof, to use for spot repair, and to provide additional protection for flashing when integrated with a reinforced fabric.

The Sikalastic®-500 systems provides tenacious adhesion with an existing roof system to form a monolithic membrane.

FEATURES & BENEFITS

- Prolongs the life of an existing roof membrane while helping to lower internal temperatures and reduce cooling costs.
- Hydrophobic – resistance to water penetration
- High tensile strength and abrasion resistance
- Excellent adhesion to a variety of roof substrates
- Ease of application - extremely fast and simple to install
- Can be used to reinforce and seal seams, penetrations, transitions, terminations, and to make spot repairs.
- Slows degradation caused by normal weathering, aging, and UV rays
- Economical - extends the life of your existing roof

WARRANTY

*See Warranty System Sheet

REQUIRED MATERIALS

- Sikalastic®-502 Primer
- Sikalastic®-500
- Sikalastic®-500 Flash
- Sika Flexitape Heavy
- High Strength Concrete Grout

SYSTEM DESCRIPTION

The Sikalastic®-500 systems for concrete are comprised of two comprehensive products to cover and protect your roof:

1. Sikalastic®-502 primer is a two component, epoxy based primer with unique penetrating, and asphaltic bleed blocking characteristics - quick re-coat times and low viscosity.
2. Sikalastic®-500 is a versatile, low VOC, single-component, high solids, liquid silicone coating designed for use as either a base coat or a top coat for asphaltic roof system.

STORAGE & HANDLING

Keep containers closed, and store in a dry, cool place away from heat, sparks, open flame, and moisture. Keep material stored above 65°F (18°C) and on wood pallets off concrete floors. Open containers should be blanketed with dry nitrogen before resealing.

ADHESION TEST

To ensure successful application of the Sikalastic®-500 always perform several adhesion tests (ASTM D-903) with the recommended primer to ensure the roof substrate will accept the coating. Do not proceed with coating system without prior testing.

SYSTEM BUILD UP

24 mils system

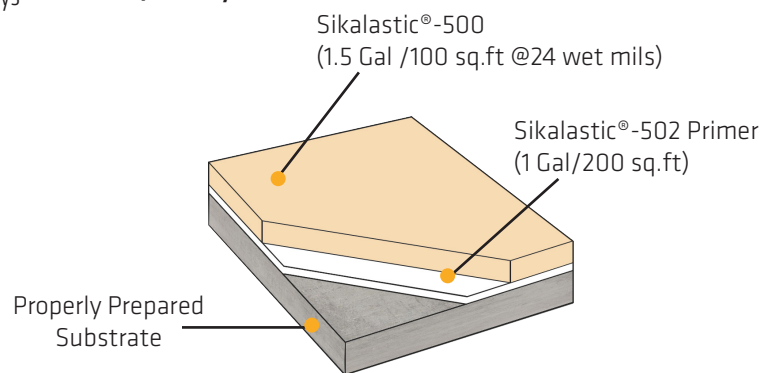

40 mils system

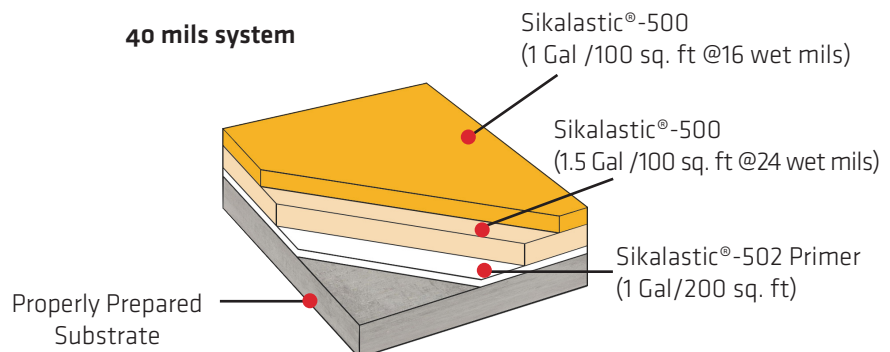

SIKALASTIC®-500 SYSTEMS SILICONE ROOF SYSTEM

BUILDING TRUST



PRE-INSPECTION

Pre-inspect roof for necessary repairs before application of coating system. Inspection should include but not limited to the following:

- HVAC flashings
- Water leakage
- Ponding water
- Substrate damage or disrepair
- Parapet wall conditions
- Proper drainage/obstructions
- Wet or damp insulation
- Copings and flashings
- Sign or display anchorage
- Sleepers & pitch pockets
- Seams, terminations, transitions, and reglets

SURFACE PREPARATION

(1) Remove all unnecessary and non-functional equipment and debris from the roof.

(2) Remove dirt, and foreign material detrimental to adhesion or application of fluid-applied roofing by thoroughly cleaning all roof surfaces with a high pressure 2,000 - 2,500 psi wash. Surfaces contaminated with oil, grease, animal fats, etc. must be removed using tri-sodium phosphate and water, or other solutions as required by job conditions and as permitted by local and federal regulations. Remove all cleaning solutions with plenty of fresh water and allow drying.

(3) Make every effort to remove asphaltic residue. Removal efforts must include use of methods such as pressure washing, scrappers, grinding, wire brushes, electrical drill wire-wheels, or other similar tools. Consider complete shot blasting and grinding when necessary. For cracks and fissures less than 1/8" wide, and all joints, stress areas, and roof penetrations prime at the theoretical rate of 1/3 gal/100 sq. ft. @ 5 wet mils, allow drying. Then detail with Sikalastic®-500 Flash. All large gaps and cracks (greater than 1/4") shall be repaired using a high-quality concrete grout. Grout must be fully cured before application of coating products. Prime cured grout at the theoretical rate of 1/3 gal/100 sq.ft. @ 5 wet mils, allow drying then detail with Sikalastic®-500 Flash shall extend a minimum of 3 inches beyond the edges of the repairs of gaps.

(4) Seal watertight using Sikalastic®-500 Flash all round projections, machine legs, sign posts, guide wire straps, inside and outside corners, cant strips, gutters, parapet walls, caps, and seal watertight all screws, seams, skylights, joints, pipes, voids, protrusions and any areas where water could enter through the roof.

(5) Clean and seal all areas around drains watertight. For added strength consider adding Sika Flexitape Heavy into the Sikalastic®-500 Flash

(6) Allow roof and other prepared surfaces to dry completely before proceeding with field priming and/or coating application. Note: Thickness values of cured membranes are averages and can vary due to finish of surface.

(7) Always check the weather prior to application. Depending on the ambient, and substrate temperatures, relative humidity, and dew point take extra time and caution when applying the system within 2 to 6 hours of precipitation and/or when

raw or freezing temperatures are experienced or anticipated. Do not apply over wet insulation or related materials.

(8) Apply Sikalastic®-502 Primer to the substrate at a theoretical coverage rate of 1/2 gal/100 sq. ft. @ 5 wet mils, and allow to dry.

COATING APPLICATION

Apply Sikalastic®-500 at the rate of 1½ gal/100 sq. ft. @ 24 wet mils, to yield a total of 24 wet mils of coverage, and allow the membrane to cure. For the 40 wet mils system, apply another topcoat of Sikalastic®-500 at 1 gal/100 sq.ft. @ 16 wet mils to yield a total coverage of 40 mils. If applying higher mil thickness of Sikalastic®-500, do not exceed 3½ gal/100 sq.ft. This could cause blisters and/or pinholes. Care should be taken to avoid sagging, pinholes, and runs of the coating on vertical, horizontal, and slanted surfaces to prevent sagging. Application rate may need adjusting if topcoat starts to sag on verticals or higher slopes. If adjusted, allow base coat and/or top coat to dry 24 hours in between coats. Additional coats maybe required to achieve required mil thickness. Sikalastic®-500 Accelerator for topcoat may be used for faster cure times and to avoid pinholes and/or blisters. Actual required application rate will depend on system specified and length of warranty.

Protection: After completion of application, do not allow traffic on coated surfaces for a period of at least 48 hours at 75° F and 50% R.H., or until completely cured.

EQUIPMENT

Spray Applied - Please consult your sika representative

Dipped and Rolled - Brushes of various sizes and a 3/8" nap roller should be used when applying on smooth surfaces such as metal.

Sikalastic®-500 System Typical Data / Physical Properties

Colors	White, Tan, Light Gray and Custom Color.
Shelf Life	8 Months
Curing (75°F-24°C, 50% R.H.)	4 Hours
Hardness Shore A, ASTM D-2240	55 ± 2%
Tear Resistance, ASTM D-624	45 lbs./in.
Tensile Strength, ASTM D-412	300 psi
Elongation, ASTM D-412	200 ± 15%
Specific Gravity	1.34
% Solids by Weight, ASTM D-2369	98%
% Solids by Volume, ASTM D-2697	98%
Viscosity at 77°F (25°C)	8,000 - 11,000 cps
VOC, ASTM D-2369-81	35.4g/L
Reflectivity	0.88
Emmissivity	0.91
SRI	112