

# SIKA® HYDROTITE PIPE PENETRATION INSTALLATION

## SIKA HYDROTITE – PIPE PENETRATION INSTALLATION INFORMATION & INSTALLATION

### INTRODUCTION

SIKA HYDROTITE is a state-of-the art hydrophilic waterstop. Comprised of a modified chloroprene rubber, SIKA HYDROTITE has unmatched durability and water sealing capacity. Expanding up to eight times its original volume when exposed to water, SIKA HYDROTITE conforms to gap variations along the joint. This action ensures complete sealing even under high hydrostatic head pressures. Due to its slim profile, excellent concrete consolidation can be expected around the waterstop, with little chance of the profile being moved out of position when concrete is placed. The small cross section allows most SIKA HYDROTITE profiles to be packaged in 10 to 25 meter rolls weighing less than 5 pounds. All SIKA HYDROTITE profiles are treated with a special delay coating to prevent them from reacting with water in fresh concrete and expanding before curing takes place. For best bonding results, SIKA HYDROTITE profiles should be applied to smooth, even surfaces, free of dirt, oil, or laitance. Maintain a minimum of 2" concrete coverage over SIKA HYDROTITE when using 3000 PSI or greater compressive strength concrete. Increase the coverage on reduced strength concrete or for SIKA HYDROTITE CJ-3030-M and CJ-1030-4M profiles.

### INSTALLATION

**New Construction:** SIKA HYDROTITE CJ, SS, RS, DS, and DSS profiles may be used to seal pipe penetrations (SIKA HYDROTITE O-Rings may be used to seal pipe penetrations that are 1" diameter or less). The SIKA HYDROTITE profile should be cut to a length just slightly less than the circumference of the pipe to be sealed. This will allow for a snug fit of the profile once the installation is complete. Ends should be cut square with a sharp knife or shears. Apply SIKA HYDROTITE ADHESIVE to the pipe surface and to the waterstop. SIKA HYDROTITE CJ-1020-2K and CJ-07253K profiles are available with an optional peel-and-stick adhesive backing for fast and easy installation. Ensure that the location will satisfy the minimum requirement for concrete coverage.

Place several drops of a cyanoacrylate adhesive (i.e. Super Glue) to the ends of the SIKA HYDROTITE profile. Immediately wrap the profile around the pipe at the location of the contact adhesive and join the ends together. Hold tightly for approximately 30 to 45 seconds, allowing the adhesive to cure. Release the ends and allow the profile to constrict onto the pipe.

### EXISTING WALL - NEW PIPE

Create an oversized cut out in the wall. Follow the procedure in the previous section for bonding SIKA HYDROTITE to the pipe. Adhere a second length of SIKA HYDROTITE to the inner circumference of the cutout, joining the ends with cyanoacrylate adhesive as described above. Use a SIKA HYDROTITE ADHESIVE if the surface is smooth and dry. A two component epoxy (such as SIKA GREENSTREAK EPOXY 7300) can be used to level rough surfaces and for bonding SIKA

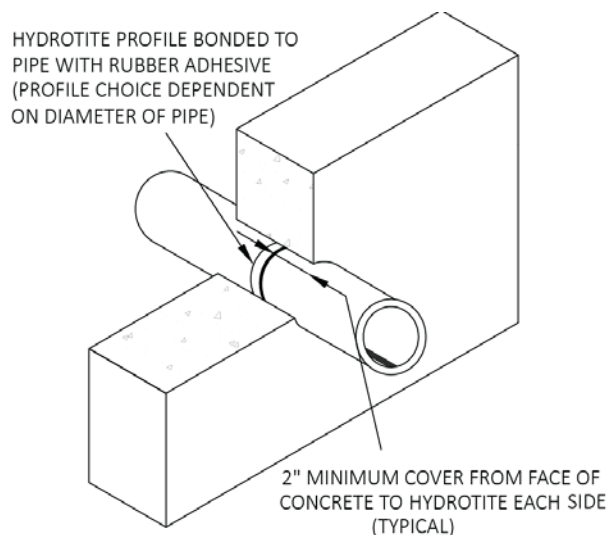

# SIKA® HYDROTITE PIPE PENETRATION INSTALLATION

Greenstreak™



BUILDING TRUST

HYDROTITE into position. Fill the annulus with a SIKA non-shrink grout after positioning both SIKA HYDROTITE profiles and the pipe.

## IMPORTANT PRECAUTIONS

SIKA HYDROTITE profiles should be used primarily in site formed concrete joints where limited movement is expected. SIKA HYDROTITE protects a joint from water migration by creating a compressive seal within the joint. Joints with excessive movement may diminish this compressive seal and compromise the effectiveness of the waterstop.

While SIKA HYDROTITE can be wet-dry cycled many times, a constantly damp or wet environment is ideal.

In order to avoid concrete cracking caused by the expansion pressure of SIKA HYDROTITE, a minimum of 2" of concrete coverage is recommended. Increase this coverage if lightweight or low strength concrete (<3000 PSI compressive strength) is used, or for SIKA HYDROTITE CJ-3030-M or CJ-1030-4M profiles.

SIKA HYDROTITE should be stored in a cool, dark, dry place. Although SIKA HYDROTITE has a delay coating to inhibit premature expansion, care should be taken to limit exposure to moisture prior to installation and placement of concrete. If SIKA HYDROTITE is installed in an expanded condition, the effectiveness of the seal will be severely reduced.

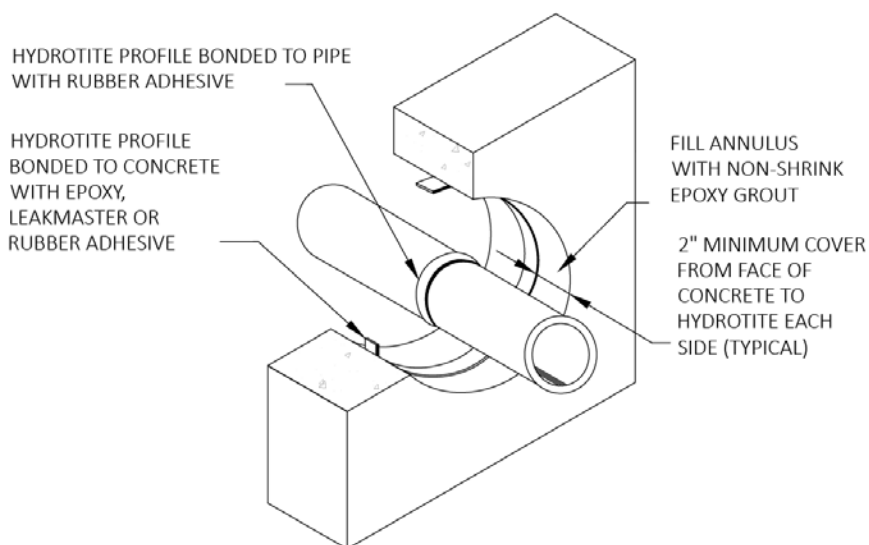

**Limited Warranty:** Sika® warrants its products to be free of manufacturing defects and that they will meet Sika's current published physical properties when applied in accordance with Sika's directions and tested in accordance with ASTM and Sika's standards. There are no other warranties by Sika® of any nature whatsoever expressed or implied, including any warranty of merchantability or fitness for a particular purpose in connection with this product. Sika® shall not be liable for damages of any sort, including remote or consequential damages resulting from any claimed breach of any warranty, whether expressed or implied, including any warranty of merchantability or fitness for a particular purpose or from any other cause whatsoever. Sika® shall also not be responsible for use of this product in a manner to infringe on any patent held by others.

**Sika Corporation - US**  
201 Polito Avenue  
Lyndhurst, NJ 07071  
United States  
Usa.Sika.com

**For More Information Contact**  
Sika - St. Louis Sales Office  
3400 Tree Court Industrial Blvd.  
63122, St. Louis, MO  
United States  
[www.USA.Sika.com](http://www.USA.Sika.com)  
Phone: 1-800-325-9504  
Fax: 800-551-5145