

DIVISION 7 - THERMAL AND MOISTURE PROTECTION
Section 07900 Joint Sealers
Primers for Elastomeric and non-Elastomeric Sealant

Part 1 - General

1.01 Summary

- A. This specification describes the coating of joints with a one-component, adhesion promoting primer prior to application of a sealant.

1.02 Quality Assurance

- A. Manufacturing qualifications: The manufacturer of the specified product shall be ISO 9001:2008 certified and have in existence a recognized ongoing quality assurance program independently audited on a regular basis.
- B. Contractor qualifications: Contractor shall be qualified in the field of concrete repair and protection with a successful track record of 5 years or more. Contractor shall maintain qualified personnel who have received product training by a manufacturer's representative.
- C. Install materials in accordance with all safety and weather conditions required by manufacturer or as modified by applicable rules and regulations of local, state and federal authorities having jurisdiction. Consult Material Safety Data Sheets for complete handling recommendations.

1.03 Delivery, Storage, and Handling

- A. All materials must be delivered in original, unopened containers with the manufacturer's name, labels, product identification, and batch numbers. Damaged material must be removed from the site immediately.
- B. Store all materials off the ground and protect from rain, freezing or excessive heat until ready for use.
- C. Condition the specified product as recommended by the manufacturer.

1.04 Job Conditions

- A. Environmental Conditions: Do not apply material if it is raining or snowing or if such conditions appear to be imminent. Minimum application temperature 40°F (5°C) and rising.
- B. Protection: Precautions should be taken to avoid damage to any surface near the work zone due to mixing and handling of the specified sealant.

1.05 Submittals

- A. Submit two copies of manufacturer's literature, to include: Product Data Sheets, and appropriate Material Safety Data Sheets (MSDS).

1.06 Warranty

- A. Provide a written warranty from the manufacturer against defects of materials for a period of one (1) year, beginning with date of substantial completion of the project.

Part 2 - Products

2.01 Manufacturers

- A. **Sikaflex Primer 449**, as manufactured by Sika Corporation, 201 Polito Avenue, Lyndhurst, NJ 07071 is considered to conform to the requirements of this specification.

2.02 Materials

- A. Primer:
 - 1. The primer shall be a one-component, brush, dauber, spray-applied material. It shall be applicable in a horizontal, vertical, and overhead joints. The primer shall cure under the influence of atmospheric moisture.

2.03 Performance Criteria

- A. Properties of the uncured primer:
 - 2. Dry time prior to sealnt installation: >30 minutes <8 hr.
 - 3. Consistency: brush-, or spray-applied liquid
 - 4. Color: clear
- B. Properties of the cured primer:
 - 1. Promotes adhesion to the following substrates:
 - a)PVC
 - b)Solvent-based enamel
 - c)PPG's Flourocarbon Duranar-finish
 - d)Kynar
 - e)ABS plastic
 - f) Plexiglass
 - g)Plexiglass DR
 - h)PPG Polycron
 - i) Rovel Plastic
 - j) Lucite
 - k)Tuffal
 - l) Urethane
 - m)Polyester/Fiberglass
 - 2. Service Range: -40F to 170F max.
 - 3. The primer shall be capable of being re-applied if necessary.
 - 4. The primer shall be acceptable for use in joints which will be subjected to total water immersion.

Note: Tests were performed with material and curing conditions at 71°-75°F and 45-55% relative humidity.

Part 3 - Execution

3.01 Surface Preparation

- A. All substrates must be clean, dry, sound, free of surface contaminants, and free of frost. Remove all traces of the old sealant, dust, laitance, grease, oils, curing compounds, form release agents and foreign particles by mechanical means, i.e. – sandblasting, etc., as approved by the engineer. Blow joint free of dust using compressed air line equipped with an oil trap.

3.02 Mixing and Application

- A. Primer:
 - 1. Shake or stir primer well before using. Apply with a brush, dauber, or spray onto the substrate covering the sides of the joint surfaces.
 - 2. If the Sikaflex sealant cannot be installed within 8 hours of priming, reprime the area is necessary

3.03 Cleaning

- A. The uncured primer can be cleaned from tools and equipment with an approved solvent. The cured primer can only be removed mechanically.
- B. Leave work area in a neat, clean condition without evidence of spillovers onto adjacent areas.

SC-098

Sikaflex® Primer 449

(for PVC, solvent-based enamel, PPG's flouorocarbon, Duranar-finish, and certain plastics)

1. Shake or stir primer well before using.
2. Brush or daub onto the substrate covering the entire joint surface.
3. Allow primer to dry from 1 to 8 hours prior to installation of sealant.

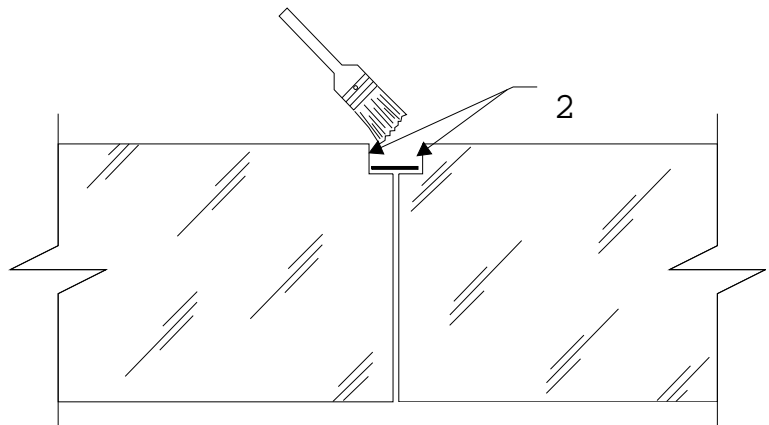
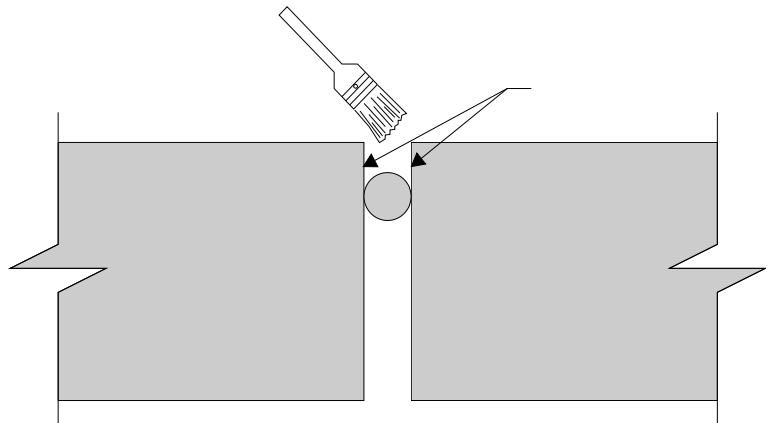

The preceding specifications are provided by Sika Corporation as a guide for informational purposes only and are not intended to replace sound engineering practice and judgment and should not be relied upon for that purpose. **SIKA CORPORATION MAKES NO WARRANTY OF ANY KIND, EITHER EXPRESS OR IMPLIED, AS TO THE ACCURACY, COMPLETENESS OR THE CONTENTS OF THESE GUIDE SPECIFICATIONS.** Sika Corporation assumes no liability with respect to the provision or use of these guide specifications, nor shall any legal relationship be created by, or arise from, the provision of such specifications **SIKA SHALL NOT BE RESPONSIBLE UNDER ANY LEGAL THEORY TO ANY THIRD PARTY FOR ANY DIRECT OR CONSEQUENTIAL DAMAGES OF ANY KIND ARISING FROM THE USE OF THESE GUIDE SPECIFICATIONS.** The specifier, architect, engineer or design professional or contractor for a particular project bears the sole responsibility for the preparation and approval of the specifications and determining their suitability for a particular project or application.

Prior to each use of any Sika product, the user must always read and follow the warnings and instructions on the product's most current Technical Data Sheet, product label and Material Safety Data Sheet which are available at www.sikaconstruction.com or by calling (201) 933-7452. Nothing contained in any Sika materials relieves the user of the obligation to read and follow the warnings and instructions for each Sika product as set forth in the current Technical Data Sheet, product label and Material Safety Data Sheet prior to product use.