

Section 03 01 00 Concrete Rehabilitation

SIKA SPECIFICATION NOTE: *This guide specification includes test methods, materials and installation procedures for SikaRepair®-224, structural repairs in parking lots, industrial plants, walkways, bridges, tunnels, ramps and dams. SikaRepair®-224 is a one-component, cementitious, ready-to-use mortar, with silica fume, fiber-reinforced with compensated shrinkage. Formulated for trowel or low pressure applications. Designed especially for vertical and head applications. It is prepared in CSI Master Format and should be included as a separate section under Division 3 – Concrete.*

Part 1 - General

1.01 Summary

This Specification shall be read as a whole by all parties concerned. Each Section may contain more or less the complete Work of any trade. The Contractor is solely responsible to make clear to the Subcontractors the extent of their Work and coordinate overlapping Work.

1.02 System description

This specification describes the patching or overlay of interior and/or exterior vertical and overhead surfaces with a pneumatically placed cementitious, silica fume, fiber-reinforced, high strength shrinkage-compensated portland cement mortar.

1.03 Related sections

Maintenance of Cast-in-Place Concrete: Section 03 01 30
Maintenance of Precast Concrete: Section 03 01 40
Maintenance of Cast Decks and Underlayment: Section 03 01 50
Maintenance of Mass Concrete: Section 03 01 70
Structural Concrete: Section 03 33 00

1.04 References

The following standards are applicable to this section:

- ASTM C-109 - Compressive Strength
- ASTM C-293 - Flexural Strength
- ASTM C-496 - Splitting Tensile Strength
- ASTM C-882 modified - Slant Shear Strength
- ASTM C-1012 – Sulfate resistance



1.05 Quality Assurance

- A. Manufacturing qualifications: The manufacturer of the specified product shall be ISO 9001 certified and have in existence a recognized ongoing quality assurance program independently audited on a regular basis.
- B. Contractor qualifications: Contractor shall be qualified in the field of concrete repair and protection with a successful track record of 5 years or more. Contractor shall maintain qualified personnel who have received product training by a manufacturer's representative.
- C. Store and apply materials in accordance with all safety and weather conditions required by manufacturer or as modified by applicable rules and regulations of local, state and federal authorities having jurisdiction. Consult Safety Data Sheets (SDS) for complete handling recommendations.

1.06 Delivery, Storage, and Handling

- A. All materials must be delivered in original, unopened containers with the manufacturer's name, labels, product identification, and batch numbers. Damaged material must be removed from the site immediately.
- B. Store all materials off the ground and protect from rain, freezing or excessive heat until ready for use.
- C. Condition the specified product as recommended by the manufacturer.

1.07 Job Conditions

- A. Environmental Conditions: Do not apply material if it is raining or snowing or if such conditions appear to be imminent. Minimum application temperature 45°F (7°C) and rising.
- B. Protection: Precautions should be taken to avoid damage to any surface near the work zone due to mixing and handling of the specified material.

1.08 Submittals

- A. Submit two copies of manufacturer's literature, to include: Product Data Sheets (PDS), and appropriate Safety Data Sheets (SDS).
- B. Submit copy of Certificate of Approved Contractor status by manufacturer.

1.09 Warranty

Provide a written warranty from the manufacturer against defects of materials for a period of one (1) year, beginning with date of substantial completion of the project.

Part 2 - Products

2.01 Manufacturer

SikaRepair®-224, as manufactured by Sika® Corporation, is considered to conform to the requirements of this specification.

2.02 Materials

Silica fume enhanced cementitious mortar:

- A. The mortar shall be a blend of selected portland cements, microsilica, fibers, and specially graded aggregates. It shall be applicable for horizontal, vertical, and overhead surfaces.
- B. The materials shall be non-combustible, both before and after cure.
- C. The materials shall be supplied in a factory-proportioned unit.
- D. The cementitious, microsilica mortar must be placeable from 3/8" (9.5 mm) in depth and greater.

2.03 Performance Criteria

Typical Properties of the mixed polymer-modified, portland cement mortar:

1. Yield	0.40 ft ³ (0.01 m ³) per bag
2. Color	Concrete gray
3. Mixing Ratio	3/4 – 7/8 gal (2.8 - 3.3 L) of liquid
4. Application Thickness	Min 3/8" (9.5 mm) Max Overhead 1-1/2" (38 mm) Max Vertical 2" (51 mm)
5. Application Temp	> 45 °F (7 °C)
6. Compressive Strength (ASTM C-109)	1 day – 4,500 psi (31.0MPa) 7 days – 8,000 psi (55.2 MPa) 28 days – 10,00 psi (69.0 MPa)
7. Flexural Strength (ASTM C-293)	28 day – 1,100 psi (7.6 MPa)
8. Splitting Tensile Strength (ASTM C-496)	28 day – 735 psi (5.1 MPa)
9. Sulfate resistance (ASTM C-1012)	1 year <0.06%
10. Chloride Ion Diffusion Resistance (ASTM C-1202 AASHTO T-277)	28 days < 500 C

Note: Tests above were performed with the material and curing conditions @ 71°F – 75°F and 45 - 55% relative humidity.

Part 3 – Execution

3.01 Surface Preparation

- A. Areas to be repaired must be clean, sound, and free of contaminants. All loose and deteriorated concrete shall be removed by mechanical means. Mechanically prepare concrete substrate to obtain a surface profile of $\pm 1/8''$ (CSP 6 or greater as per ICRI Guidelines) with a new exposed aggregate surface. Area to be patched shall not be less than $3/8''$ in depth.
- B. Where reinforcing steel with active corrosion is encountered, sandblast the steel to a white metal finish to remove all contaminants and rust. Where corrosion has occurred due to the presence of chlorides, the steel shall be high pressure washed after mechanical cleaning. Prime steel with 2 coats of Sika® Armatex® 110 EpoCem as per the Product Data Sheet (PDS).

3.02 Mixing and Application

- A. Material is to be applied by conventional wet spray equipment. Consult PDS.
- B. Placement Procedure Wet Process: At time of application, surface should be Saturated Surface Dry (SSD) but hold no standing water. Apply material by spraying or troweling for repairing vertical or overhead surfaces. Shoot the material perpendicular to the surface. This minimizes rebound, creates the smoothest pattern (reduces bumps) and properly encases the rebars. The velocity of the shotcrete is sufficient if, at a distance of 18 to 24", the shotcrete pattern flattens out on contact with the surface and the rebars are encased. After applying the material, allow to stiffen for approx. 10 minutes before removing bumpy areas with a trowel. If a another layer is desired, allow the material to reach initial set. This will take anywhere from 45 minutes to 2-4 hours depending on mix consistency, mix and ambient temperature, wind conditions and humidity. Begin and finish a given patch on the same day.
- C. As per ACI recommendations for portland cement concrete, curing is required. Moist cure with wet burlap and polyethylene, a fine mist of water or a water-based* compatible curing compound. Moist curing should commence immediately after finishing and continue for 48 hours. Protect newly applied material from rain, sun, and wind until compressive strength is 70% of the 28 day compressive strength. To prevent from freezing cover with insulating material. Setting time is dependent on temperature and humidity.

*Pretesting of curing compound is recommended.
- D. Adhere to all procedures, limitations and cautions for the polymer-modified portland cement mortar in the manufacturers current printed Product Data Sheet (PDS) and literature.

3.02 Cleaning

- A. The uncured silica-fume portland cement mortar can be cleaned from tools with water. The cured silica-fume, portland cement mortar can only be removed mechanically.
- B. Leave finished work and work area in a neat, clean condition without evidence of spillovers onto adjacent areas.

SikaRepair®-224

Wet spray

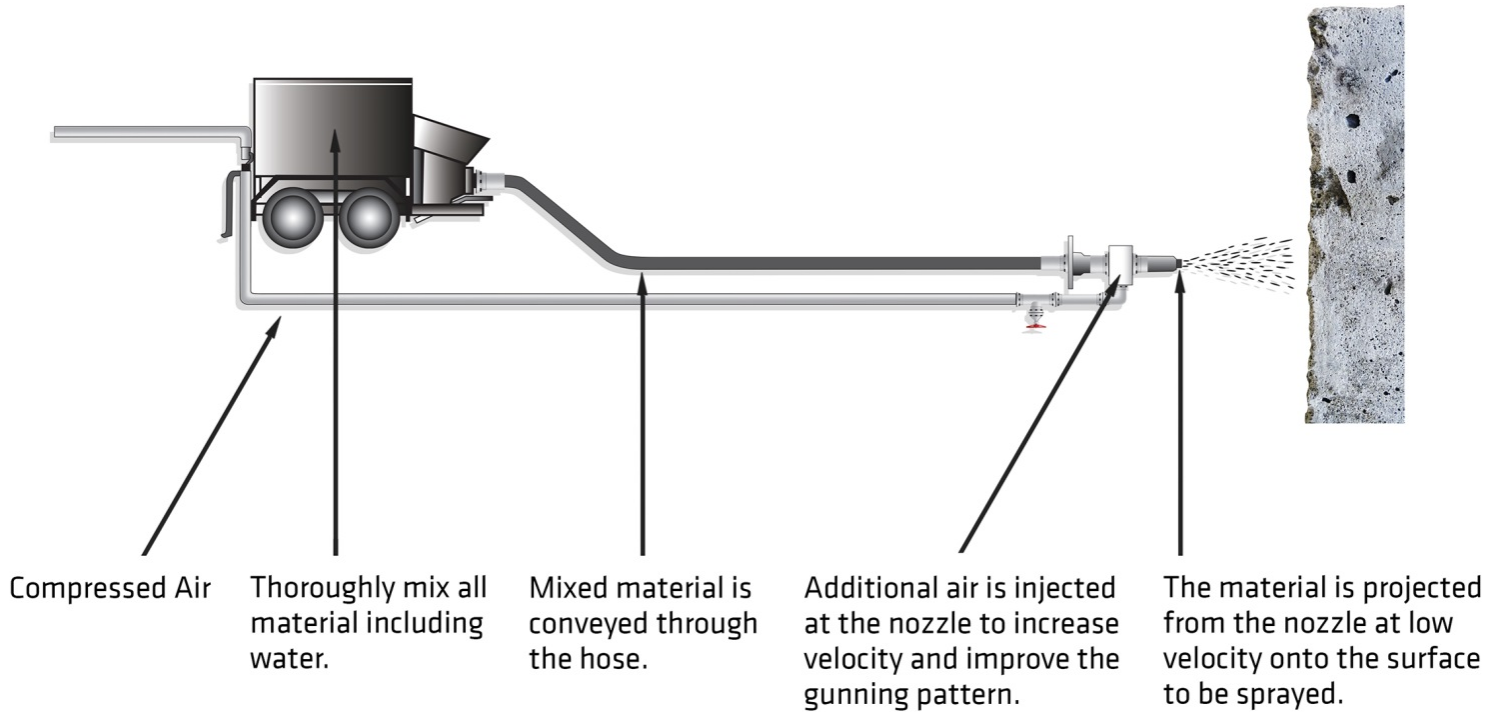

Concrete Restoration Systems by Sika Corporation, 201 Polito Avenue, Lyndhurst, NJ 07071

The preceding specifications are provided by Sika Corporation as a guide for informational purposes only and are not intended to replace sound engineering practice and judgment and should not be relied upon for that purpose. Sika Corporation makes no warranty of any kind, either express or implied, as to the accuracy, completeness or the contents of these guide specifications. Sika Corporation assumes no liability with respect to the provision or use of these guide specifications, nor shall any legal relationship be created by, or arise from, the provision of such specifications. SIKA SHALL NOT BE RESPONSIBLE UNDER ANY LEGAL THEORY TO ANY THIRD PARTY FOR ANY DIRECT OR CONSEQUENTIAL DAMAGES OF ANY KIND ARISING FROM THE USE OF THESE GUIDE SPECIFICATIONS. The specifier, architect, engineer or design professional or contractor for a particular project bears the sole responsibility for the preparation and approval of the specifications and determining their suitability for a particular project or application.

Prior to each use of any Sika product, the user must always read and follow the warnings and instructions on the product's most current Product Data Sheet, product label and Safety Data Sheet which are available online at <http://usa.sika.com/> or by calling Sika's Technical Service Department at 800-933-7452. Nothing contained in any Sika materials relieves the user of the obligation to read and follow the warnings and instruction for each Sika product as set forth in the current Product Data Sheet, product label and Safety Data Sheet prior to product use.